

TOP 5

Food and Beverage Applications

Optek[®]
inline control

english
deutsch
español
portuguese
русский язык
中文
日本語
français
italiano



optek Instruments for the Food and Beverage Industry

Models AF16-N, TF16-N and DTF16 are high precision turbidity sensors. Models AF16-F and AF26 are high precision color sensors. Models AF45 and AF46 are high precision UV absorption sensors. All are designed for inline operation.



optek C4000 Photometric Converter

C4000 - Photometric Converter

The Control 4000 photometric converter is designed for optek ultraviolet (UV), visible (VIS), near-infrared (NIR) absorption and scattered light based sensors and is able to multiplex several sensors. The graphic display can show absorbance, transmittance, and concentration in real-time and in any unit of measure such as **CU, OD, %-Tr., ppm (DE), EBC, FTU, g/l, APHA** and many others.

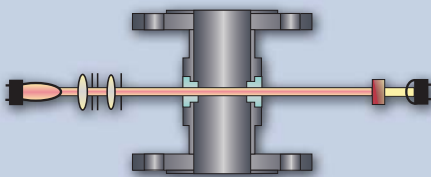

Model AF16-N/AF16-F

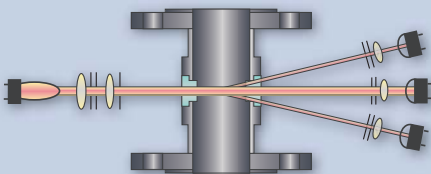

Model TF16-N

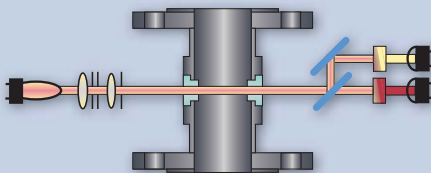

Model AF26

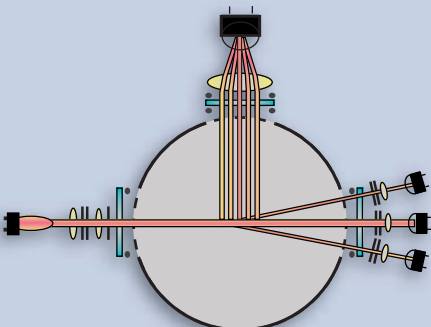

Model DTF16

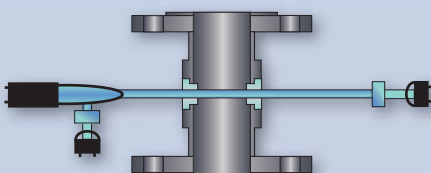

Model AF45

Turbidity

AF16-N Single Channel Absorption (NIR)

A special tungsten lamp produces a constant light beam that passes through the process medium. The attenuation of the light intensity, caused by absorption and/or scattering by dissolved and/or undissolved substances, is detected by a sealed silicon photodiode. The AF16-N uses light from 730 - 970 nm (NIR) to measure solids concentration independent from color or color changes. Depending on the optical path length, measuring ranges from high % to 0 - 100 ppm (parts per million) are possible.

TF16-N Dual Channel Scattered Light (11°)

Light scattered from particles in the medium is detected by eight hermetically sealed silicon photodiodes at an angle of 11°. At the same time, the unscattered light is detected by a reference photodiode. The sensor measures extremely low particle sizes and concentrations. Additionally, high particle concentrations can be monitored independent of color on the direct reference detector.

DTF16 Haze Control Triple beam scattered light optical design (11° / 90°)

Precisely measures 11° / 90° scattered light with light compensation and additional absorption measurement for high concentrations.

Color

AF16-F Single Channel Absorption (VIS)

Similar to the NIR absorption sensor, the AF16-F measures in the visible (VIS) range (385 - 670 nm) at selected wavelengths. A sealed silicon photodiode is used to detect the loss of light due to an increase in the color. optek sensors measure in various color scales such as **APHA/Hazen, Saybolt, ASTM, ASBC, EBC, ICUMSA** and many more.

AF26 Dual Channel Absorption (VIS/NIR)

Selected combinations of optical filters make it possible to focus on specific wavelengths ensuring suitable adaptation to the application. While the AF16-F uses one wavelength, an AF26 is equipped with an internal beam splitter making it possible to measure two wavelengths simultaneously. The second wavelength can be used to compensate for varying background turbidity and any lamp intensity variation to ensure the highest level of precision and long-term performance.

UV Absorption

AF45 Single Channel Absorption (UV) AF46 Dual Channel Absorption (UV)

Precisely measures concentration with lamp intensity compensation.

For over 25 years, optek has focused on measuring process liquids through their interaction with light in facilities all over the world. Although global, optek remains a family owned company with a team of more than 100 qualified, customer-driven professionals.

Our confidence is born from experience. With the expertise of more than 30,000 installations worldwide, our value to the customer resides in providing a superior product that pays back. High quality materials withstand the toughest process conditions including aggressive media, high temperature, and

high pressure applications. Cleanability is ensured using high quality wetted materials, superior design, as well as sapphire optical windows.

As a global partner to various industries, optek offers the most advanced technologies including superior signal amplification, inline calibration support, PROFIBUS® PA, FOUNDATION Fieldbus™ and multilingual user interfaces for easy onsite operations.

Our support ensures long term satisfaction with programs such as “Speed-Parts” and “SwapRepair” to provide our

customers sustainable operations and minimized downtime at the lowest cost of ownership.

Conformity to international (ISO 9001), industry-specific (FM/ATEX approval) or company standards is easily achieved with optek. Wherever process composition is controlled, the name optek has become synonymous with world-class products and support.

Optimize your process with optek inline control.



Content	
TOP 5	Food and Beverage Applications
TOP 1	Filtration and Separation 04
TOP 2	Concentration and Color 06
TOP 3	Identification (Interface Detection/CIP) 07
TOP 4	Bleaching and Blending 09
TOP 5	Condensate and Cooling Water 10
	System Calibration 11
	Contact 12

Please see separate application brochure for brewery applications or visit: www.optek.com

04 | Filtration

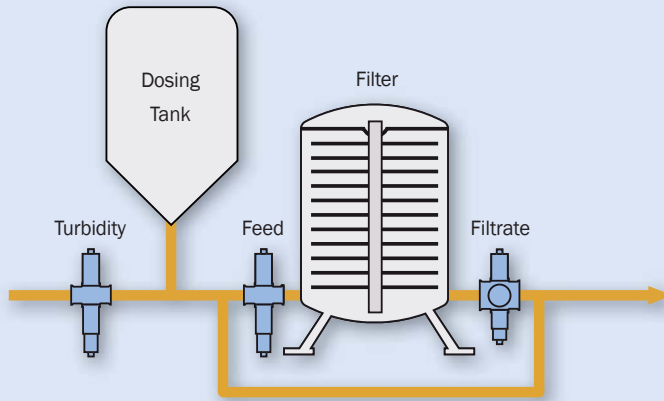

Filtration Control 11°/90°

The optek Haze Control / DTF16 relies on a dual angle scattered light measurement for precise quality control during final filtration independent of color and color changes. Using this sensor downstream of the filter detects filter breakthroughs, preventing “out of spec” product while ensuring product quality and clarity at each filtration step.

Factory Calibration

Each optek DTF16 is factory calibrated to **FTU** standards which correlate to **EBC, ppm (DE), ASBC** or others.

Feed Monitoring

Using an optek AS16-N or AF16-N, the turbidity in the feed line can be monitored, allowing precise feed control

while preventing filter clogging or blinding. This additional sensor can be connected to your Haze Control / DTF16 system without the need for an additional converter.

Filter Backwash Optimization

The optek AS16-N or AF16-N used for feed monitoring can also be used to optimize your filter backwash process by measuring the turbidity in the water, saving time, energy and conserving water usage.

Filter Aid Dosage

Dosage of filter aids like diatomaceous earth (DE) can be controlled with optek absorption or scattered light sensors. Optimizing filter aid usage reduces costs and ensures consistent product quality.

Filter Setup Monitor

Using the reference channel allows measurements at higher turbidity levels to monitor and control the filter pre-coat cycle.

Typical Applications:

- **Edible Oil:**
 - Filtering of nickel catalyst for reuse, (turbidity measurement)
- **Sugar Refining:**
 - Monitoring of the filtrate stream for turbidity
- **Wine:**
 - Monitoring of filtration and stabilization
- **Soy Sauce**
 - Monitoring of filtration
- **Fruit Juice Concentrate**
 - Monitoring filter breakthrough and clarity



optek Haze Control DTF16



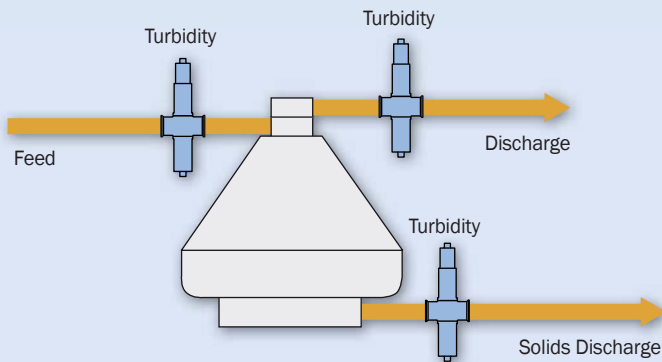

optek C4000 Photometric Converter

Outlet (Centrate) Control

Centrifugal separators equipped with a NIR absorption based photometer AF16-N or AS16-N on the outlet can eliminate needless discharges and initiate them only when solids carry-over is detected in the centrate stream. Counting the frequency of these discharges is an indicator of incoming solids loads, which can be used to adjust the flow rate to allow maximum separation performance in high load conditions, and allows maximum throughput at low load conditions. Optionally, a scattered light sensor TF16-N can be installed instead of a NIR absorption sensor to ensure the lowest measuring ranges.

Feed Control

Adding a second NIR absorption based photometer AF16-N or AS16-N to the feed line and measuring incoming loads directly allows immediate response to varying process conditions, including diverting high solids slugs to prevent plugging up a separator bowl. One mishap like this costs more than the analyzers used to prevent it.

Concentrate Control

The concentrate stream of a separator can be equipped with a NIR absorption based photometer AS16-N or AF16-N using a very short optical path length to accurately correlate absorption measurements directly to weight-percent. This enables yield measurement and control of product quality.

Typical Applications:

- **Edible Oil:**
 - Winterization process to remove saturated glycerides or waxes
- **Dairy:**
 - Butter oil clarification, whey cream separators
- **Tea:**
 - Separation to remove leaves after boiling
- **Fruit Juice:**
 - Separation of fruit pulp from juice
- **Wine:**
 - Separation of must

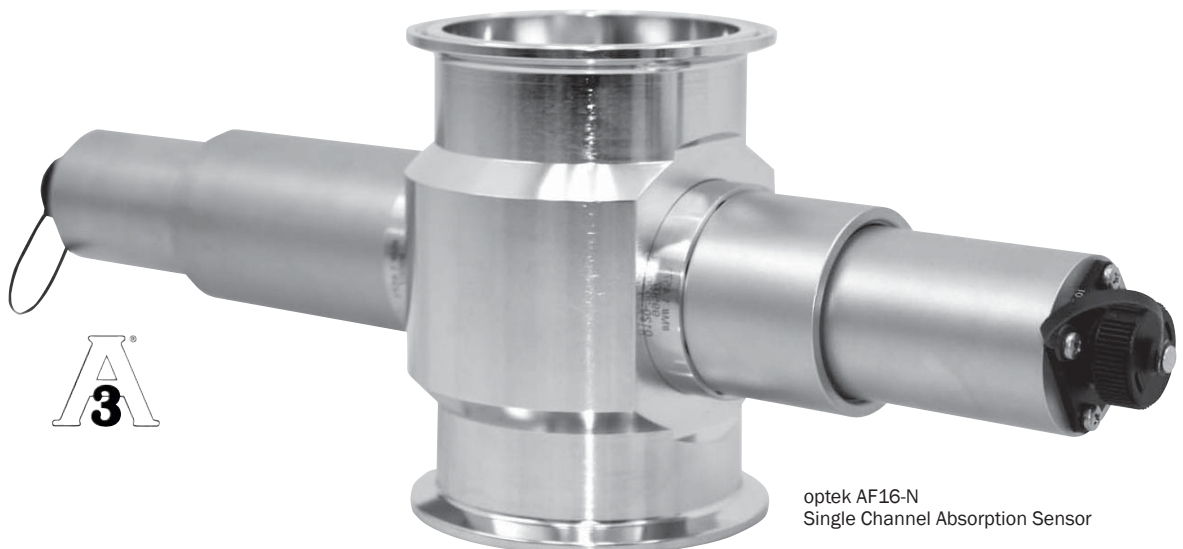

optek AF16-N Single Channel Absorption Sensor

06 | Concentration and Color



optek C4000 Photometric Converter

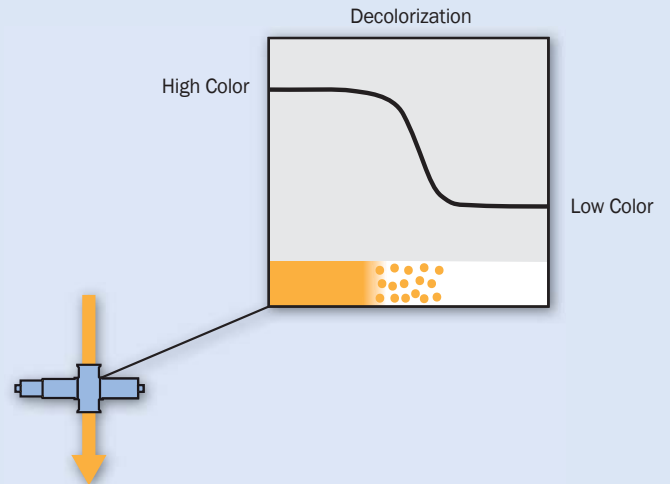

Color Measurements

Process color measurements of liquids are critical in maintaining precise process control and meeting product quality specifications. Color changes indicate other process variables such as overheating, dilution ratios, dissolved impurities and finished product appearance. Monitoring color inline using optek photometers enables precise, real-time control of color dosing, color removal or color avoidance.

Dual Wavelengths

Selected combinations of optical filters make it possible to focus on specific wavelengths ensuring suitable adaptation to the application. The AF26 is equipped with a beam splitter making it possible to measure two wavelengths simultaneously. The second wavelength can be used to compensate for (varying) background turbidity. Subtracting the absorbance signal of the reference channel from the primary, visible channel signal gives a pure

color measurement. Using the C4000 converter, the measured value is easily correlated to any required unit, such as **APHA/Hazen, Saybolt, ASTM, ASBC, EBC, ICUMSA** or others. The converter displays the measurement locally and transmits the signal to a PLC or DCS using analog outputs or PROFIBUS® PA communication or FOUNDATION Fieldbus™.

Concentration Measurement

The measurement is represented in concentration units (CU) at a given wavelength and relates to the concentration of constituents in question that interact with light.

Process Optimization

The detection of impurities, reduction of product losses and the real-time assurance of product quality can be obtained by the use of inline photometers. In addition, inline photometers greatly reduce laboratory and production costs, eliminate human error and prevent environmental damage.

Typical Applications:

- **Edible Oil:**
 - Yellowness of oil for consistent product color quality
 - Chlorophyll concentration detection
 - Red phosphorus monitoring
- **Sugar Refining:**
 - ICUMSA/RBU color standard for refined sugar quality (optek C4000 has mA input for Brix measurement and calculation capability)
- **Frying Oil in Food Processing:**
 - Optimize usage/color and turbidity measurements (an optek high temperature application up to 240 °C / 464 °F)
- **Soft Drinks:**
 - In filling lines as a quality control
 - Color measurement for dosing or blending control
- **Blancher:**
 - Monitor/optimize make-up water based on starch content in water
- **Fruit Juice:**
 - Monitoring solids/pulp concentration in fruit juice



optek AF26-VB Dual Channel Absorption Sensor with calibration option



optek Calibration Accessories (NIST-traceable)

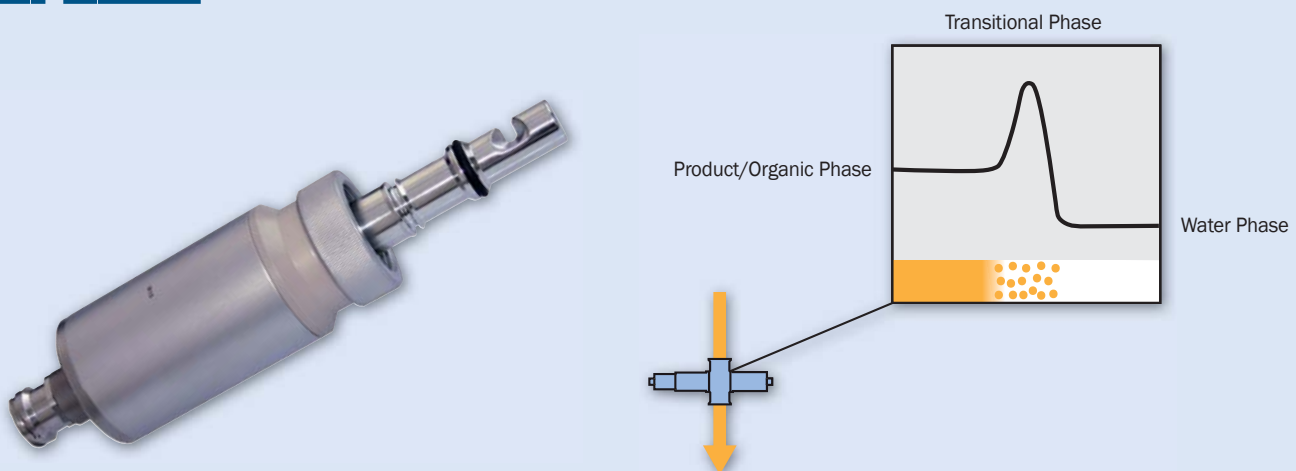

Interface Detection / Phase Separation

Precise process interface detection with a single channel absorption photometer (optek AS16 or AF16) is the easiest and most effective technique available to food and beverage processors today to reduce product losses. In a large food production facility, the sheer number of change-over operations can cost thousands of hectoliters of product and by-products each week.

In today's economy, recovering product is essential to maintain a profitable business. However, the costs go beyond the product alone. Water as the push-out medium is also a commodity and has an inherent cost to procure and treat. Product and water going needlessly down the drain are large contributors to plant effluent and the costs to treat it. Local municipalities may also be involved: applying charges to the volume of effluent and even fines if solids load or **BOD** limits are exceeded. Gaining control of plant interface functions not only makes sense, it's also environmentally friendly.

Increased Product Quality

Product losses are no longer an issue when detecting different phases inline. Faster product changeovers are possible with continuous optek inline measurements. There are certain advantages inline photometers provide over traditional conductivity measurements. These include fast response time and excellent repeatability in the use of relays for automatic diversion, resulting in higher product quality and improved process control.

optek offers customized solutions based on your process media and automation requirements. optek also manages phase separations in a wide range of wavelengths, from ultraviolet (UV) to visible (VIS) and near-infrared (NIR).

Typical Applications:

- **Dairy:**
 - Interface detection of milk/water, cream/water, yogurt /water
- **Winery:**
 - Interface detection of wine/water, water/wine
- **Soft Drinks:**
 - Interface detection of product / water, water/product
- **Fruit Juice:**
 - Interface detection of juice/water
- **Confectionery:**
 - Phase separation of water/milk/ caramel



optek AS16-N Single Channel Absorption Probe

08 | Identification (CIP)

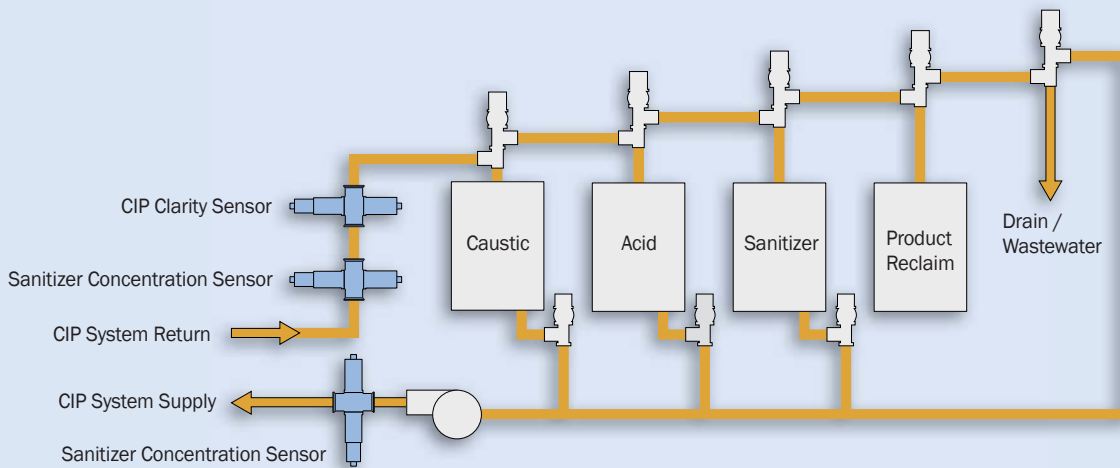

Clean-In-Place (CIP)

Many manufacturing facilities require (CIP) systems to clean tanks, pumps, valves, filters, heat exchange units as well as the process piping. The use of CIP increases plant efficiency, improves safety and ensures product quality. However, achieving these benefits requires monitoring and control of the CIP process to optimize heat, cleaning agents and water consumption.

CIP Optimization

Precise process interface detection with a single channel NIR absorption based photometer (optek AF16-N or AS16-N) is typically installed at the CIP return points where it is beneficial to measure the exact interface on rinse water. Inline photometers can also be used to monitor the sanitizer concentration to control the CIP process, for validation routines, and in some cases, to monitor the residual after cleaning.

Sanitizer Concentration

Chemical concentration has always been a difficult measurement using traditional conductivity sensors.

Changes in pH, temperature, or other unexpected compounds can all affect conductivity devices. To compensate for these issues, plant operators often overdose chemicals to ensure adequate sterilization, then extend line flushes to ensure it is removed.

Sanitizer Optimization

By installing an optek UV / VIS or NIR absorption sensor on the feed line, exact concentrations are monitored, optimizing performance, while reducing chemical usage. These sensors are also compensated to eliminate any influence from turbidity or the presence of other compounds. In addition, with immediate response times, sanitizer and water usage is greatly reduced.

CIP Application Benefits:

- Reduced water usage
- Reduced sanitizer consumption
- Reduced wastewater costs
- Reduced cycle times
- Reduced operating costs
- Increase in available process time
- Documented sanitizer concentration
- Rapid return on investment



optek AF16-VB-N Single Channel Absorption Sensor with Calibration Option

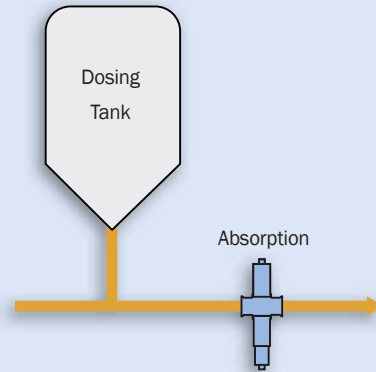

Inline Control

Monitoring color inline using optek photometers enables precise, real-time control of color dosing, color removal, color quality or color avoidance.

Typically, process color measurements are made by taking samples from the process piping and analyzing them in a lab either visually or using a laboratory analyzer. optek colorimeters can immediately detect color changes in process liquids directly in the pipeline.

Benefits

- Real-time measurements / less need for lab analysis
- Consistent product quality
- Measurement wavelengths and optical path lengths selected to match process requirements
- Immediate feedback on process changes

Typical Applications:

- **Edible Oil:**
 - Control of bleaching process/ bleach dosing/control of filter breakthrough
- **Potato Processing:**
 - Dosing control of caramel color, annatto or tumeric
- **Sugar Refining:**
 - Decolorization of sugar, monitoring of the fine liquor, ICUMSA/RBU color measurement
- **Fruit Juice:**
 - Precise juice color monitoring

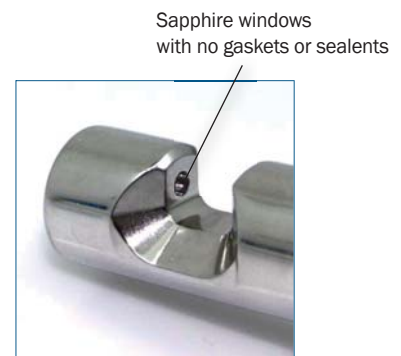

optek AS16-F Single Channel Absorption Probe



optek AS16-F Single Channel Absorption Probe



optek AF26-VB Dual Channel Absorption Sensor with Calibration Option

10 | Condensate and Cooling Water

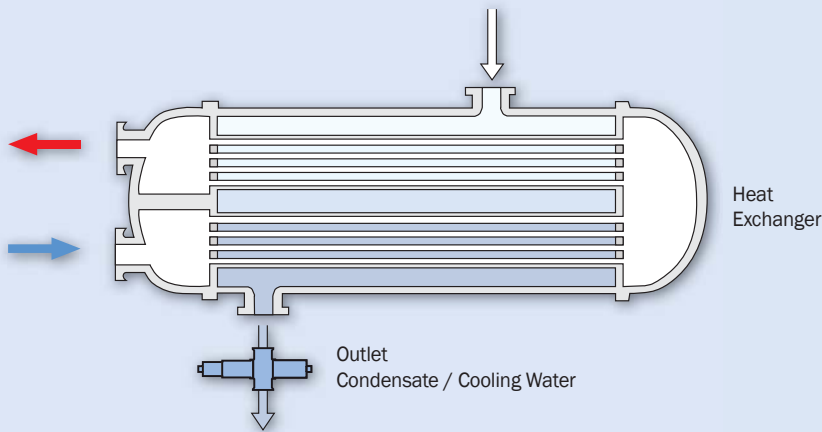

optek C4000 Photometric Converter

Heat Exchanger Leak Detection

Heat exchanger leak detection is an important application for many processors. Companies in all industries increasingly demand measurement of oil contents in the ppm range. For this purpose, inline turbidity meters have become standardized worldwide as a reliable solution.

By using optek turbidity meters in heat exchanger cooling/heating lines, a pinhole leak in a plate can now be detected and repairs can be made before a catastrophic breakdown occurs. Also, operating costs are reduced because heat exchanger downtime can be scheduled to minimize process downtime. This ensures proper operation of the heat exchanger and reduces the risk of bacteriological growth in cooling/heating lines.

Condensate

optek photometers ensure that condensate is free from particulates allowing it to be reused for boiler feed or other processes. This has proven to be an extremely beneficial process improvement: Reducing water usage, treatment chemicals, and wastewater costs.

Carryover

There is a chance of carryover in any area where water is used to heat or cool the process stream. An optek inline photometer is an excellent tool for immediate detection of process trace particulates.

In applications where the process stream consists of undissolved oil or solids, a TF16-N scattered light turbidity meter can detect the total particle content. By measuring in the near-infrared (NIR) range, the measurement will not be affected by color or color changes.

With optek instruments, process temperatures up to 240 °C (464 °F) are manageable.

Typical Applications:

• Dairy:

- Heat exchanger leak detection in pasteurization process
- COW water monitoring in evaporation process

• Coffee:

- Instant coffee evaporator monitoring, trace product in heating / cooling lines

• Fruit Juice:

- Heat exchanger leak detection / carryover in cooling/heating lines

• Edible Oil:

- Condensate monitoring to identify trace oil in condensate water going to the cooling tower



optek TF16-EX-HT-N
Scattered Light Dual Channel Turbidity Sensor



Member of the FM Global Group

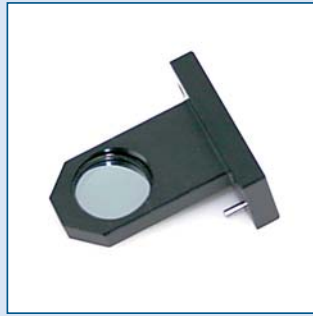

optek calibration accessories have been specially designed for nonintrusive calibration and verification of optek systems.

UV Sensors

Three series of solid filters are available to ensure confidence in measurements. The UV-L filter series is used to calibrate photometric accuracy and linearity. The UV-B filter series verifies integral blocking and the UV-S filter series tests for long term stability of the sensor.

VIS/NIR Sensors

A special series of solid filters is available for each wavelength (range) to ensure best measurement performance. The calibration filters are used to calibrate photometric accuracy and linearity.

NIST-traceable

All optek filters ship with NIST-traceable certification (National Institute of Standards and Technology). optek laboratory is equipped with a high quality, NIST-traceable spectrophotometer assuring quality and quick turn around time for recertification of filters.

Concept

Advantages of optek calibration concept include:

- only 1 filter (set) for multiple sensors ensures identical calibration
- only the filter needs to be sent back for recertification, while the sensor remains operating.

- **Calibration Filters UV-L**

Nominal absorption:
0.45, 0.9, 1.8 and 2.4 CU

- **Calibration Filter UV-B**

Nominal absorption:
> 3 CU

- **Calibration Filters UV-S**

Nominal absorption:
Application specific

- **Calibration Filters VIS-L**

Nominal absorption:
0.45, 0.9 and 1.8 CU

- **Calibration Filters NIR-L**

Nominal absorption:
0.45, 0.9 and 1.8 CU

- **Calibration Case**

Holds up to 7 calibration filters

- **Calibration Cuvette**

The unique calibration cuvette enables product calibration without need to interfere with the process line. It allows users to create a correlation of absorption signals to the concentration of product or an equivalent substance, creating an easy link from lab to process.





Germany

optek-Danulat GmbH
Emscherbruchallee 2
45356 Essen / Germany
Phone: +49 201 63409 0
Fax: +49 201 63409 999
E-Mail: info@optek.de



USA

optek-Danulat Inc.
N118 W18748 Bunsen Drive
Germantown WI 53022 / USA
Phone: +1 262 437 3600
Toll free call: +1 800 371 4288
Fax: +1 262 437 3699
E-Mail: info@optek.com



Singapore

optek-Danulat Pte. Ltd.
25 Int'l Business Park
#02-09 German Centre
Singapore 609916
Phone: +65 6562 8292
Fax: +65 6562 8293
E-Mail: info@optek.com.sg



China

optek-Danulat Shanghai Co., Ltd.
Room 718 Building 1
No.88 Keyuan Road
Pudong Zhangjiang
Shanghai, China 201203
Phone: +86 21 2898 6326
Fax: +86 21 2898 6325
E-Mail: info@optek-danulat.cn

中国

优培德在线测量设备（上海）
有限公司
上海张江科苑路88
号德国中心718
室 邮编:201203
电话:+86-21-28986326
传真:+86-21-28986325
E-Mail: info@optek-danulat.cn

Please visit our website for contact details of our local distributors in other countries.

www.optek.com